

CT16

16- channel telemetry system

Including signal conditioning for strain gage, thermo couples, Pt100, ICP, POT and high-level inputs



- 12 bit resolution,
- Simultaneous sampling of all channels
- Anti aliasing filters
- Signal bandwidth 16 x 0 ... 375Hz (320kbit)
- Signal bandwidth 16 x 0 ... 45Hz (40kbit)
- Distance up to 500m

General functions:

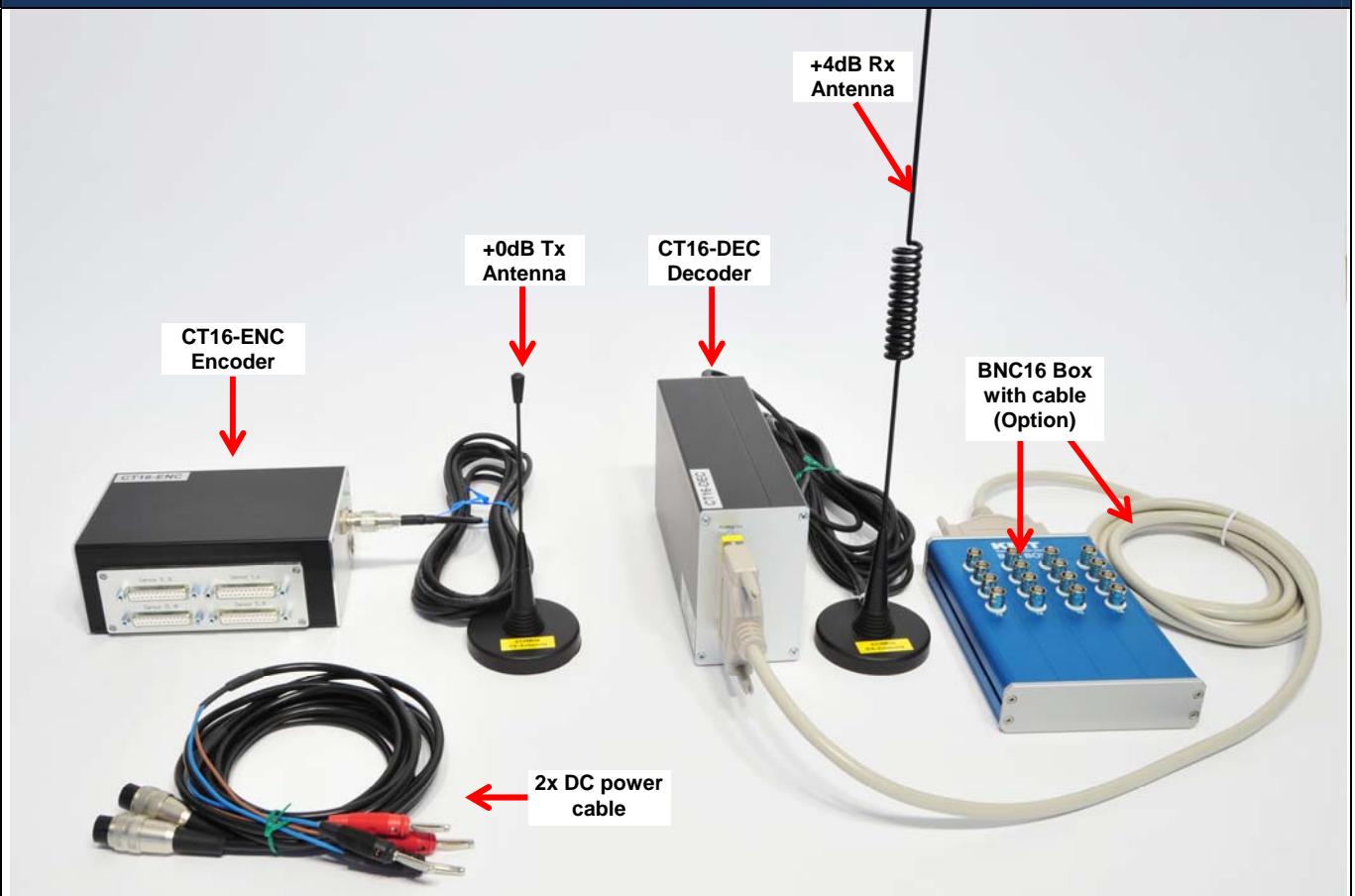

The CT16 Compact is a 16-channel telemetry system with integrated signal conditioning for sensors, wireless digital transmission and analog reproduction. The conditioned measured values are routed via anti-aliasing filter to a 12-bit A/D converter, simulate sampling of all channels, encoded in PCM format and transferred to the HF transmitter as modulation variables. Dynamic range is 72dB with a signal-to-noise ratio of approximately 70dB. Four different carrier frequencies available with the 40kbit transmitter (433.3 to 434.5 MHz range) and enable a signal bandwidth of 16 x 0-45 Hz. With the 320kbit/s transmitter is only one carrier frequency available in the 433,9 MHz band and enable a signal bandwidth of 16 x 0-375 Hz.

Various configurations of different sensor modules are possible like signal conditioning for strain gages (STG), thermocouples type K (Th-K), thermo sensors Pt100, ICP sensors, potentiometer sensors (POT) and also Voltage inputs (+/-5 or +/-10V). Mixed configuration available.

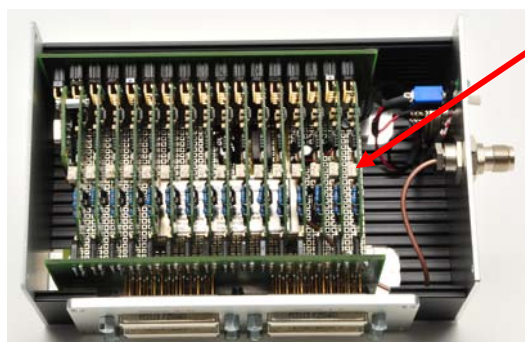

Specify CT-xx modules at order!!

Frequency table	Cut off frequency from anit-aliasing filter (-3dB) and scanning rate (see red)
Bit rate	16 CH.
320 kbit/s	375 Hz (1632 Hz)
40 kbit/s	47 Hz (204 Hz)

CT16-ENC (Encoder)



Front side with the Sensor inputs

CT-STG V1:

Sensor:	strain gage, ≥ 350 Ohms
Bridge completion:	full, half and quarter-bridge competition 350Ohm
Excitation:	4 VDC (fixed), short-circuit protection up to 20mA
Gain:	200 or 1000 - selectable by solder jumpers Optional Gain: 250-500-1000-2000 with new CT-STG V2 module
Offset	Zero adjustment by potentiometer or <u>optional</u> Auto-zero function (which is not lost by power-off), offset range up to 80% of full scale.

CT-TH-K-ISO:

Sensor:	thermo-couple, type K (with cold junction compensation)
Temperature measuring range:	-50°C to +1000°C (other on request) with galvanic isolation

CT-PT100:

Sensor:	resistance temperature detectors (RTDs) with resistance of 100 ohm
Temperature measuring range:	-100°C to +500°C

CT-VOLT:

High-level inputs:	+/- 5 Volt or +/- 10 Volt (other ranges on request)
--------------------	---

CT-ICP:

Sensor:	For ICP® sensor inputs, Current exc. 1, 4, and 10mA Signal gain x 2, 4, 8, 16, 32 - Signal bandwidth 3 Hz up to 3000Hz (depended of transmitter)
---------	---

CT-POT:

Sensor:	Potentiometer Sensor >350 Ohms to 10kOhm
Excitation:	4 VDC (fixed)

System Parameters:

Channels:	16
Resolution:	12 bit A/D converter with anti aliasing filter, simultaneous sampling of all channels
Line-of-sight distance:	500 m with 10mW transmitting power (433MHz Band, 40kbit, FSK modulation)
Powering:	10-30V DC
Power consumption:	400 mA (at 12V) using 16 STG sensors at 350 Ohms and 40kbit transmitter
Analog signal bandwidth:	*(-3dB cut-off frequency)
16-channel version	16 x 0 ...45Hz* with <u>40 kbit/s transmitter</u> (433.3 - 433.7 - 434.1 - 434.5 MHz)
16-channel version	16 x 0 ...375Hz* with <u>320 kbit/s transmitter</u> (1x 433.9 MHz)
Dimensions:	165 x 105 x 65mm (without connectors)
Weight:	0.970 kg (without cables)
Transmission:	Digital PCM Miller format - FSK
Transmission Power:	10mW
Operating temperature:	- 20 ... +70°C
Housing:	Aluminum
Humidity:	20 ... 80% no condensing
Static acceleration:	100g in all directions
Shock:	200g in all directions

MT32-DEC16 Receiver unit for max 16 Channels output via 37 pol. Sub D

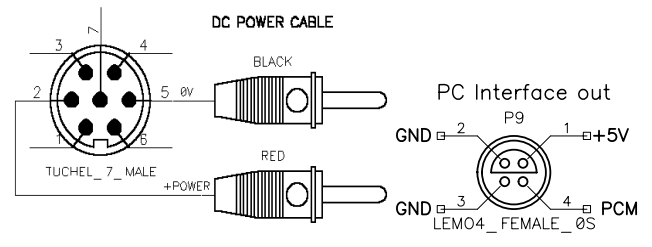
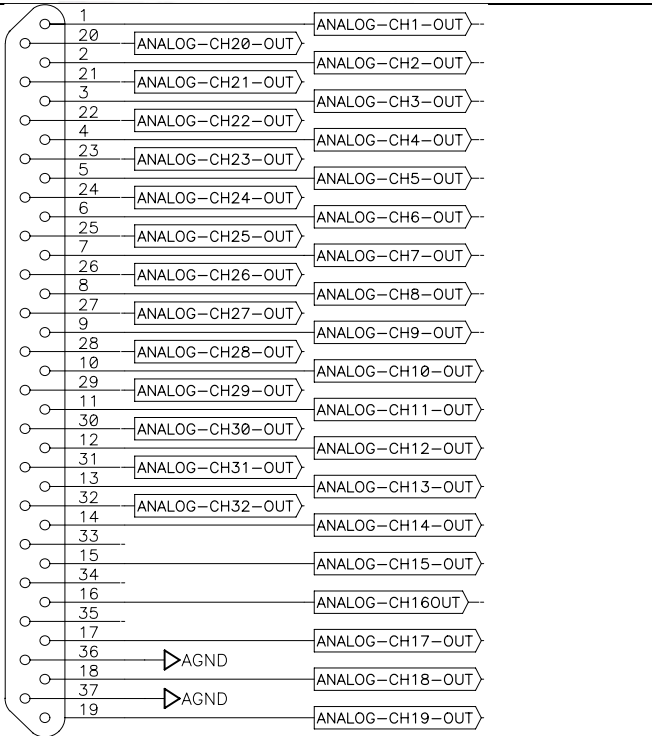
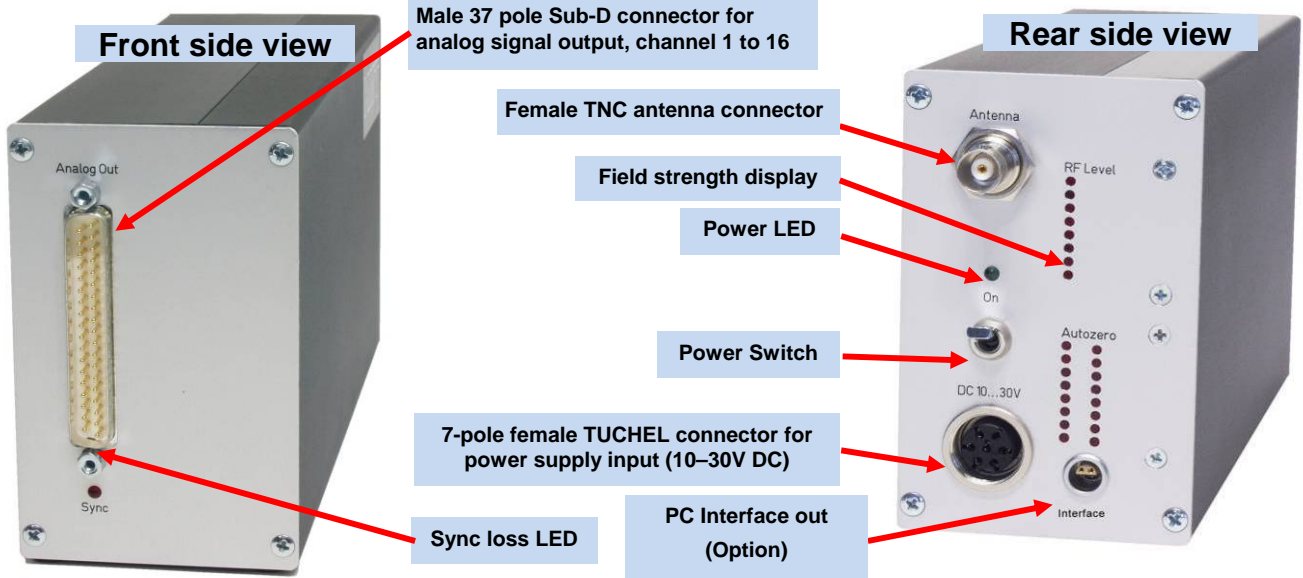

MT32-DEC16 System Parameters:

Channel:	16, +/-5V analog outputs via Sub-D male socket
Resolution:	12 bit D/A converter, with smoothing filter
Dynamic:	72dB
Power supply input:	10-30 VDC, power consumption 3 Watt
Current consumption:	300mA at 10V, 100mA at 30V
Transmitter carrier frequency:	433.3 MHz 320kbit/s, 433.3 - 433.7 - 434.1 - 434.5 MHz 40kbit
Transmission:	Digital PCM Miller Format - FSK
Dimensions:	205 x 105 x 65mm
Weight:	1.25 kg without cables and antenna
Overall system accuracy between encoder input and decoder output:	+/-0.25% without sensor influences
Environmental	
Operating:	-20 ... +70°C
Humidity:	20 ... 80% not condensing
Vibration:	5g Mil Standard 810C, Curve C
Static acceleration:	10g in all directions
Shock:	100g in all directions