

PEGASEM WST

Non-Contact Rotary Transducer for Sensor Signals

Target Specification



Features

- Designed for shaft-end mounting
- Two or four analogue measuring channels
- Programmable Amplifiers for Strain Gauges or Thermo Couples (K-type)
- Programmable Offset Compensation
- 5 VDC Power Supply capable of driving for 4 bridges (350 Ω -type or higher)
- Two or four voltage outputs (4.192 VDC, 12 bit)
- Maximum bandwidth 5 kHz per channel
- Long Term Rotational Speed up to 3000 revolutions per minute
- High durability and lifetime by non-contact signal transmission
- Optional pulse output with 128 or 1024 pulses per rev.
- Optional voltage output for revolution speed
- Waterproof housing according to IP65

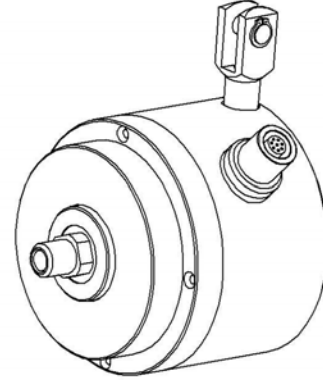

Applications

- Brake Disk Temperature Sensing
- Vehicle ABS Testing
- Vehicle ESP Testing
- Torque Measurement on rotating parts
- Power Train Measurements

Concept

A rotary transformer transfers energy and setup data to the rotating section of the unit while measurement data is sent back to the stationary section through a high speed infrared transmission line. Because of the PEGASEM WST's ability to substitute mechanical sliprings in many applications, it is also called a *Non-Contact Slipring Transducer*. Because the WST does not use mechanical contacts, better transfer quality and extra long life are achieved compared with classic sliprings, even under harsh environmental conditions. Yet, the overall price of the WST is very competitive.



MOTION MEASUREMENT SYSTEMS

BRENT RIJNOVEAN

WWW.BRENDELASSOCIATES.COM

PHONE: 313.729.9898
BRENT@BRENDELASSOCIATES.COM

24407 ROCKFORD STREET
DEARBORN, MI 48124

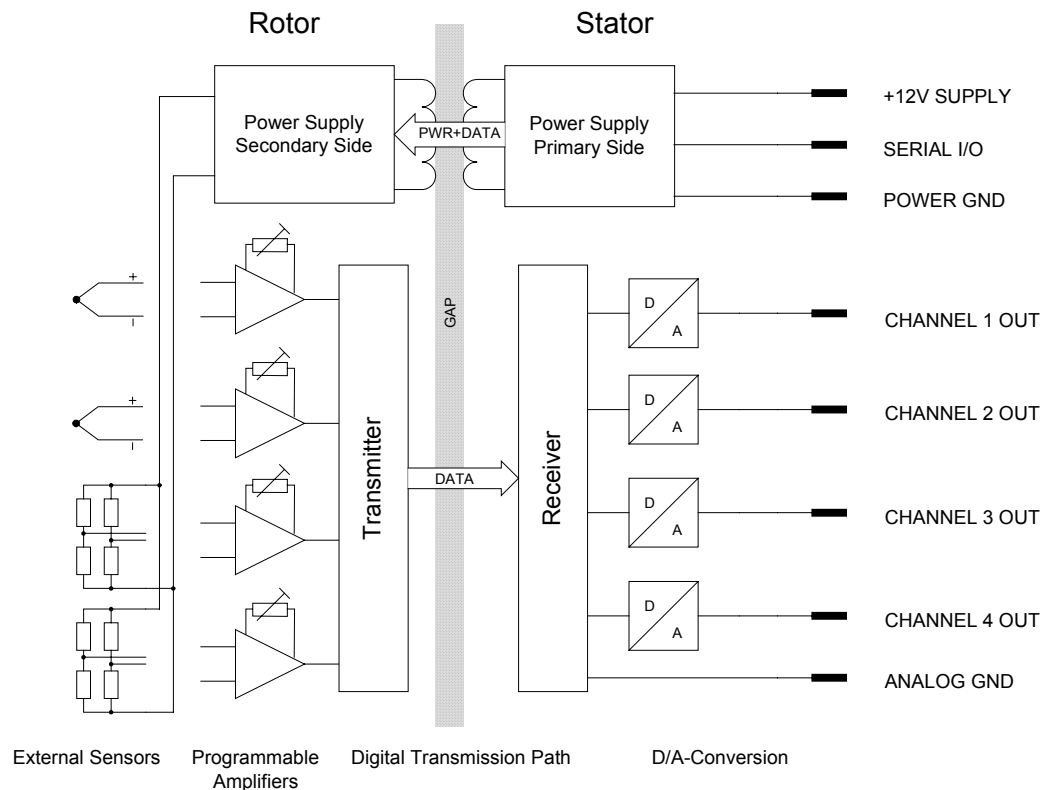

WST Block Diagram

Example shows for 4 sensor channels (2 thermo couples and 2 strain gauges, no pulse channel)

Mounting and Cabeling

The PEGASEM WST has been designed to fit onto the PEGASEM MMS Modular Mounting System for vehicle hubs. This allows easy attachment to nearly any vehicle hub and is suitable for short and long-term tests. It also can be used in applications, where shaft-end mounting is possible. The rotary hollow shaft comes with open wires for the sensors to be connected. If the WST is to be used together with the PEGASEM MMS Modular Mounting System a terminal board and a sheet-metal hood are available. It sits on the slotted disk that is part of the MMS. From there the sensors can be easily connected. The terminal board also includes a temperature sensor for the internal cold junction compensation of the TC-channels. On the stationary side waterproof Lemo-Type Push-Pull-Connectors are used. The analogue signals are available on an 8-pole female socket. On devices with pulse option a further 6-pole connector for the digital signal lines is used.

Sensor Programming

Before shipment the sensor will be factory programmed to the sensivity and offset values defined by the customer when ordering. This results in a transducer unit that can be used *out of the box*. For adapting the WST to different applications we offer an optional Windows Software that allows the user to reprogram the device in the lab or the field. The software comes with an interface box and a cable to connect the WST to the serial COM port on the PC.

Pricing

An important advantage of the PEGASEM WST is its very competitive price. As the WST already contains programmable amplifiers, the system cost for a wheel sensing solution is often much lower than when using classic sliprings and separate amplifiers. In various applications it also competes with short distance, high frequency telemetry, against which it also has a substantial price advantage. The cost of a WST-System depends on the number of measuring channels, the required wheel mounting options and the cables. Please ask for a detailed quotation fitting your specific requirements.

Available Versions

Standard	
WST-2TC	Two-Channel Version for K-Type Thermo Couples with cold junction compensation, -20°C to 1000°C, resolution 1 °C
WST-2SG	Two Channel Strain Gauge Version, 5V-Bridge Power Supply, Resolution 12 bit
WST-2SG-2TC	Four-Channel Version, for 2 Strain Gauges and 2 Thermo Couples. Features see above.
WST-4TC	Four Channel Version of WST-2TC
WST-4SG	Four Channel Version of WST-2SG
Optional	
PULSE-128	Additional Channel with 128 Pulses per rev. Index and Analogue Speed Output
PULSE-1024	Additional Channel with 1024 Pulses per rev. Index and Analogue Speed Output

Technical Data

SG-Channel	Min	Typ	Max	Unit
Signal Resolution		12		bit
Output Voltage	0	2.048	4.19	V
Programmable Sensivity for full scale output	10		1000	mV
Programmable Offset Compensation Range	-1000		+1000	mV
Bridge Power Supply Voltage	4.99	5.00	5.01	V
Bridge Power Supply Voltage (4SG Type only)	2.99	3.00	3.01	V
Minimum Bridge Resistance per channel	350			Ω
Channel Sampling Rate		10		kHz
TC-Channel	Min	Typ	Max	Unit
Signal Resolution		10		bit
Temperature Range with K-Type Thermo Couples	-20		1000	°C
Output Voltage @ 0 °C		1.000		V
Output Voltage @ 1000 °C		3.000		V
Channel Sampling Rate		0.1	10	kHz
Pulse Channel 128	Min	Typ	Max	Unit
Pulses per Revolution		128		
Analogue Rotational Speed Output ¹⁾	0		4.19	V
Analogue Speed Output Update Rate ²⁾	10 ³⁾		100	Hz
Incremental Pulse Level	0		5	V
Index Pulse Level ⁴⁾	0		5	V
Pulse Channel 1024	Min	Typ	Max	Unit
Pulses per Revolution (HighRes Version)		1024		
Analogue Rotational Speed Output ¹⁾	0		4.19	V
Analogue Speed Output Update Rate ²⁾	10 ³⁾		1000	Hz
Incremental Pulse Level	0		5	V
Index Pulse Level ⁴⁾	0		5	V
Power Supply				
Supply Voltage	8	12	30	VDC
Supply current @ 12VDC		tbd	100	mA

¹⁾ The relationship between Speed Output Voltage and Actual Speed is programmable. It also depends on the wheel size.

²⁾ The speed update rate is proportional to the pulse frequency at lower speeds but never exceeds the maximum specified value.

³⁾ @ zero speed (v = 0)

⁴⁾ TTL-compatible pulses. The index pulse duration is equal to one incremental pulse. Index not available on all versions.